



US Patent 7,380,733 B2



*Variable Rate Ready
IsoBus Ready*

Truck Mount

Three Hopper - Independent Variable Rate



IS TRIAD RIGHT FOR YOU?

- BBI Binary™ Manifold Precision Agriculture Ready
- Advanced Technology for the most sophisticated farmer!
- Large High Tech Farm?
- Ready to CASH IN on the Promise of Precision Agriculture?
- Spread your fields when YOU are ready to spread.

Your Lowest "Cost In Use" Spreader

- True - Three Material - Independent Variable Rate - allows you to maximize the technology of precision agriculture.
- UHMW and Stainless Steel reduces corrosion issues and extends the life of the spreader.
- UHMW Bearing Back keeps bearings clean resulting in longer bearing life and fewer failures.
- Proprietary MagnaSpread system delivers a wider, flatter, more consistent pattern.
- Dual Rack and Pinion gate prevents jams.
- Overhead Spinner Motors are ABOVE the chemical resulting in extended motor life.
- BBI spreaders are "Option Rich" and can be customized to your specific application.
- One-piece CNC machined UHMW Comb Cover prevents streaking in the field.

- Save Fuel & Time
- Lower Maintenance Expense

BBI "Cost in Use" Calculator		
	BBI	Other
Fuel Consumption gal / hour	7.0	7.0
Cost of Fuel \$ / gal	\$ 4	\$ 4
Fuel Cost per hour	\$ 28	\$ 28
Speed (mph)	10.0	10.0
Swath (ft) Fertilizer	80	60
Effective Driving Interval	80	60
Acres per Hour	97.0	72.7
Acres to Cover	10,000	10,000
Hours per application	103.1	137.5
Fuel Cost per application	\$ 2,888	\$ 3,850
Applications per Year	2	2
Fuel Cost per Year	\$ 5,775	\$ 7,700
Spreader Life (years)	7	7
Fuel Cost - Life of Spreader	\$ 40,425	\$ 53,900
Fuel Savings (Life of Spreader)	\$ (13,475)	-25.0%
Hours Saved (Life of Spreader)	(481.3)	-25.0%

* Values used in this example are representative of average numbers and are not intended to be specific to all applications

See Our Authorized Seller

www.BBISpreaders.com DRIVING VALUE

BBI Spreaders
470 South Wayside Street
P.O. Box 630
Cornelia, GA 30531

Phone (800)282-3570
Local (706)778-2767
Fax (706)778-2787
Email sales@bbispreaders.com



TRIAD

US Patent 7,380,733 B2



*Variable Rate Ready
IsoBus Ready*

Truck Mount

Three Hopper - Independent Variable Rate

Patented - Truck Mount - Wide Swath - Precision - Three Material Hoppers with Independent Variable Rate

Control - State of the Art Fertilizer Spreader for large acreage farms

Terminology: **(TTH)** (Triad Truck Mount Hydraulic Conveyor)

(4518) (45 Degree Sides on Main Hopper, 18" Conveyor)

Heavy Duty Tandem Section Direct Mount Pump - Driven by Truck PTO 35 Gallon Reservoir, Flow Control and Relief

Length 201", Width 130", Height 68" from rail to hopper top with 2 x 8" boards

BBI BINARY™ HYDRAULIC MANIFOLD SYSTEM: Combines the hydraulic controls for the conveyor and spinners into one control manifold. It includes proportional manual speed control for both spinners and conveyor. Pilot operated relief is standard. A dump valve and a GR is standard for the conveyor. The modularity of the BBI Binary Manifold allows for quick easy conversion to GR option and to electronic control.

Rate Control and Guidance: Factory Supplied systems are available.

Electronic Controls	STD	OPT
Variable Rate Control and Guidance Systems Available		X
Hopper		
Main Hopper #1 210 cu ft struck 45	X	
Hoppers #2 and #3 are 84 cu ft per hopper struck	X	
Bolt on Hopper	X	
304 Stainless Steel	X	
409 Stainless Steel		X
Self Contained Hydraulic System	X	
Heat Shrink Wrapped Hydraulic Fittings	X	
2 x 8" Extension Boards Standard	X	
Rail Length 176" (Standard 13' Floater Body) (CA = 112")	X	

Conveyor	STD	OPT
18" Stainless Steel Mesh Chain		
Spinner		
24" MagnaSpread System		
Overhead Hydraulic Spinner Motors		
Stainless Steel Spinners & Fins		

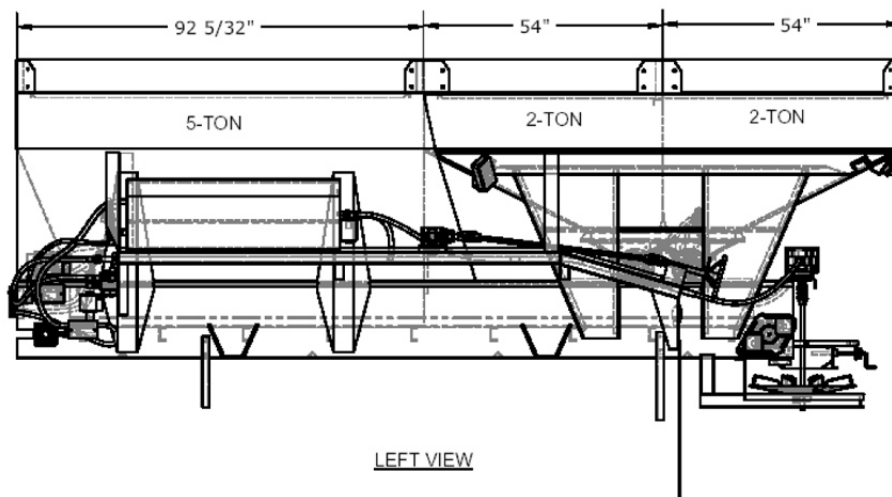

LEFT VIEW

www.BBISpreaders.com **DRIVING VALUE**

"State of the Art"
Electrostatic Paint Process

* Custom Colors Available
Primed with a rust inhibiting alkyd primer then top-coated with high gloss enamel. Two Color Paint is an Option.

BBI Spreaders
470 South Wayside Street
P.O. Box 630
Cornelia, GA 30531

Phone (800)282-3570
Local (706)778-2767
Fax (706)778-2787
Email sales@bbispreaders.com