



with the C18 Job Computer

CenterLine® 250 BBI

TABLE OF CONTENTS

CENTERLINE 250/IC18 QUICK START GUIDE..... 1

CHAPTER 1 - PRODUCT OVERVIEW 5

 KEY FUNCTIONS..... 6

 STARTUP SEQUENCE 6

 CENTERLINE 250 BBI SYSTEM DIAGRAM..... 6

 BBI CAN SYSTEM WITH IC18..... 7

CHAPTER 2 - IC18 OPERATION SCREENS 9

CHAPTER 3 - IC18 MENU NAVIGATION 11

 STARTUP SEQUENCE11

 USER SETUP.....11

Application Rate 12

Density Factor..... 12

Gate Height 12

Tonnage..... 12

Flow Factor 13

Amount Remaining..... 13

Step %..... 14

Application Rate Test 14

Calibration - Start Calibration..... 16

Warnings 17

Amount Remaining Is Low 18

Regulating Outside Of Application Rate 19

Spinner RPM Too Low..... 19

Minimum Hydraulic Motor RPM Cannot Be Reached 19

No Can Speed Available..... 19

No Memory Left 19

File Saving Failed 19

Simulated Speed Is Active 20

Stop Spreading 20

 SYSTEM COUNTERS..... 20

Trip 20

Campaign 21

Campaign - View..... 21

Campaign - Delete 22

Total 22

Save Counters	22
Print Trip Counters	23
MACHINE	23
Machine Setup	23
Work Width	24
Empty Bed	24
Empty RPM	24
Speed Sensors	24
Master Switch	26
INFORMATION SYSTEM	27
Language	27
Software Version	28
Hardware Version	28
Diagnostics	28
PC Communication	30
CHAPTER 4 - CENTERLINE® 250 OVERVIEW	31
CHAPTER 5 - CENTERLINE® 250 START UP	33
GPS STATUS LIGHTS	33
IMPLEMENT DISCONNECTED	33
CENTERLINE 250 SETUP MODE	33
BRIGHTNESS AND CONTRAST	34
SWATH WIDTH	34
ISOBUS BROADCAST OPTIONS.....	35
UNITS OF MEASURE	35
EXTERNAL COM PORT.....	36
CHAPTER 6 - CENTERLINE® 250 - GUIDANCE OPERATIONS	37
GPS STATUS LIGHTS	37
REFERENCE SCREENS	37
GUIDANCE SCREEN - MARK A-B	37
OPERATION.....	38
GUIDANCE SCREEN (NAVIGATION VIEW)	38
OPERATION FUNCTION KEYS.....	38
GUIDANCE OPERATION - MODES	38
STRAIGHT A-B GUIDANCE.....	39
CURVED A-B GUIDANCE.....	40
RETURN TO POINT.....	40
A+ NUDGE FEATURE.....	41

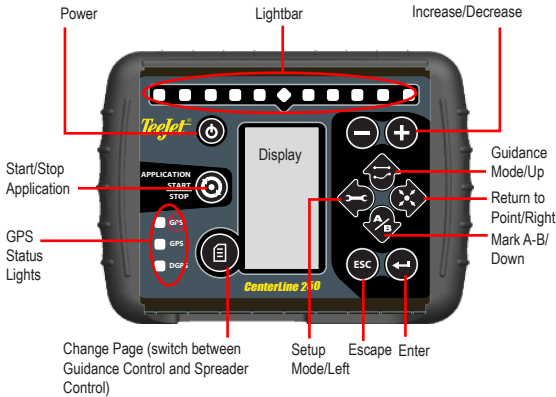

CENTERLINE 250/IC18 QUICK START GUIDE









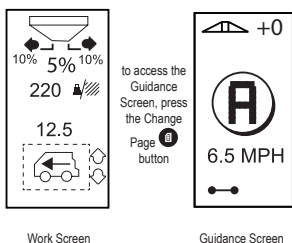

SPREADER CONTROL QUICK START

- Power ON the system by pressing the **Power** button.
- If using GPS for swath guidance or ground speed source, allow approximately **3 minutes for DGPS (Green light)** status light to come on and for best accuracy to be achieved.
- To access **User Setup**, press the **Enter** button.
- Use the **Arrow** buttons to navigate and adjust settings in the menus and to enter values. Use the **Enter** button to enter the Settings Menu and the sub-menus and to save entered values and settings. Press the **Escape** button to revert to the previous step without saving the values and to abort alarms.
- Select **User** and press the **Enter** button.
- Select **Application Rate** and press the **Enter** button. Program Rate and press the **Enter** button to save changes and exit.
- Select **Density** Factor and press the **Enter** button. Program Density and press the **Enter** button to save changes and exit.
- Select **Gate Height** and press the **Enter** button. Program gate height to match actual gate opening and press the **Enter** button to save changes and exit.
- Select **Tonnage** if **Tons per Acre (ON)** is preferred instead of **Pounds per Acre (OFF)**. Press the **Enter** button to select **ON** or **OFF**. Press the **Escape** button to exit.
- Select **Amount Remaining** to enter the beginning weight of product loaded. Press the **Enter** button to save changes and exit.
- Press the **Escape** button to exit User Setup.
- Select **Counters**, then **Trip to Select, View, or Delete** counters. Press the **Escape** button twice to exit Counter Setup.
- Select **Machine**, then **Work Width** to program spreader swath width. Press the **Enter** button to save changes and exit.
- To **Fast Empty** the loaded bed, select **Machine**, then **Empty Bed**. Be sure that spreader gate is opened to desired height. Press the Start/Stop Application button to run or stop the conveyor. Press the **Escape** button to exit.
- Press the **Escape** button to exit out to main working screen.
- To **Power OFF** the console, press and hold the **Power** button for 3 seconds.

GUIDANCE CONTROL QUICK START GUIDE

1. Power ON the system by pressing the **Power**  button.
2. Allow approximately 3 minutes for DGPS (Green light) status light to come on and for best accuracy to be achieved.
3. Use the **Change Page**  button to change screen view from **Spreader Control** to **Guidance Control**.





4. Press the **Setup**  button to enter **Guidance Setup mode**.
5. Select **Brightness/Contrast**   to change the appearance of the display. Press the **Enter**  button to save changes and exit.
6. Select **Guidance Swath Width**  to program desired **Active Swath Width**. Press the **Up or Down Arrow**   buttons to select the **Guidance Width** or the **Application Width** as the Active Swath Width.
7. Press the **Enter**  button to save changes and exit.

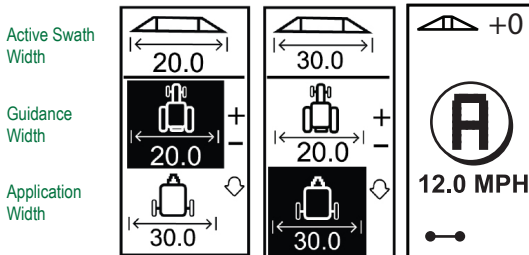

NOTE: Only the *Guidance Width* can be programmed in the *Guidance Setup mode*. The *Application Width* is the working spreader swath width programmed in *Machine Setup* and is used to regulate the output of the spreader. Typically, both the *Guidance Width* and the *Application Width* should be the same value.

WARNING: Steering the vehicle and spreader on a different swath distance than the programmed output of the spreader will result in misapplication of product applied.

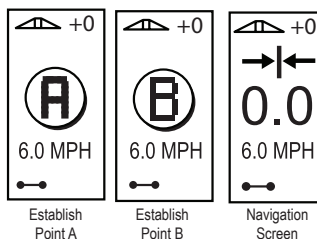

7. Press the **Guidance Mode**  button to select **Straight A-B** or **Curved A-B** guidance pattern.
8. Drive to the desired location of **Point A**. While the vehicle is in motion, press the **Mark A-B**  button to establish **Point A**. "Point B" will be displayed on the screen. Drive to the location of **Point B** and press the **Mark A-B**  button again to establish the **A-B guideline**. The CenterLine 250 will immediately begin providing navigation information with the lightbar and Navigation screen.



9. Press the **Change Page**  button to view the **Guidance** or **Application Control** screens. During Guidance view, press the **Enter**  button to enter into **Navigation View** (Bird's eye view).

Press the Change Page  key to change the screen views.

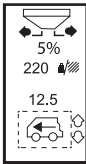

Application Control





Guidance Screen



Press the Enter  key to view the Birds Eye View.

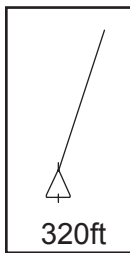
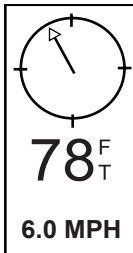

Birds Eye View

10. **Return to Point** - Press the **Return to Point**  button to establish a point in memory. To navigate back to the established point, press the **Return to Point**  button again. The Return to Point screen will be displayed and will provide navigation assistance to return to the established point. Press the **Enter**  button to view the **Navigation View** (Bird's eye view) screen.



11. **A+ Nudge Feature** - The A+ Nudge feature allows the existing A-B guideline to be shifted to the vehicle's current location. Press the **Mark A-B**  button immediately followed by pressing the **Plus**  button.
12. To **Power OFF** the console, press and hold the **Power**  button for 3 seconds.

CHAPTER 1 - PRODUCT OVERVIEW

The TeeJet CenterLine® 250 BBI with the IC18 job computer is an ISO11783 compliant system that combines both GPS swath guidance and spreader application rate control. The CenterLine 250 is a simple-to-use console that allows the operator to input desired application rate, swath width, product density, and gate height. The IC18 job computer communicates with the CenterLine 250 guidance controller, allowing for optimum spreader control. The system accumulates applied acres and volume applied for monitoring and record keeping purposes.

The IC18 provides the following features:

- Complete Overview - the information menu provides a complete overview of the application process.
- Constant Monitoring - constant monitoring and warnings of irregularities in the application process allow for immediate action by the operator.
- Precise spreader application rate control by using high quality hydraulic flow control valve, sensors, and connections. The IC18 is built in a sealed, durable enclosure.
- Loadable Language Tool - Enables OEM customers to add new languages to the system.

The CenterLine 250 provides the following features:

- Versatile GPS Guidance in a compact, portable package.
- LED Lightbar guidance plus a graphical display for complete guidance information.
- High-quality, 5 Hz internal GPS engine with external antenna.
- Simple setup gets you up and running in no time.
- Straight-line (parallel) and curved A-B guidance modes.
- Integrated look-ahead functionality anticipates vehicle's future position.

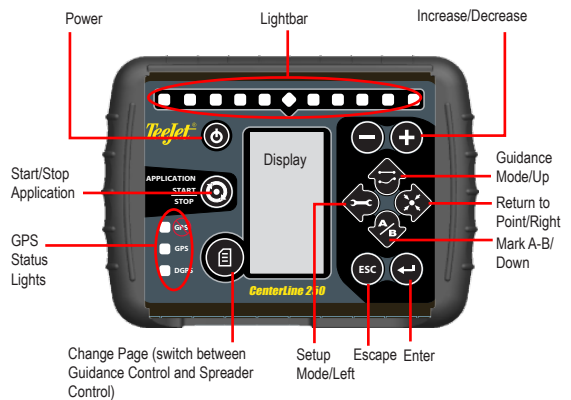

- Return-to-point feature.
- Durable, sealed rubber keypad is easy to see and provides good tactile feedback.
- Provides RADAR-like speed signal output for use with other control systems that require a ground speed signal.
- GPS Guidance - the CL250 provides lightbar guidance by means of the built-in high-quality GPS receiver.
- GPS Speed - provides high accuracy and eliminates the need for speed sensors.





KEY FUNCTIONS

Press the Power  button to start up the CL250 console. Press and hold the Power button for 3 seconds to power down the CL250 console.

Use the Start/Stop Application  button to start or stop the spreader. The spreader can be started or stopped using this key both in Operation Mode and in Guidance Mode. The spreader can be stopped at any time both from the Operation Mode and from the menus by pressing the Start/Stop Application button.

Press the Change Page  button to switch between the IC18 Spreader Mode and the GPS Guidance Mode. Press the Increase/Decrease  buttons to increase or decrease the Step %.

Use the Arrow  buttons to navigate and adjust settings in the menus and to enter values. Use the Enter  button to enter the Settings Menu and the sub-menus and to save entered values and settings. Press the Escape  button to revert to the previous step without saving the values and to abort alarms.

STARTUP SEQUENCE

Power up the system by pressing the Power  button.

Upon power up, the CL250 will perform the following:

- Display copyright and software version screen for four (4) seconds with a black background.
- Display copyright and software version screen for three (3) seconds with a white background.
- Display splash screen.
- Detect if GPS data are present (this occurs simultaneously within the display screen sequence).
- If an implement controller is added to the system, the Implement Control Screen will be displayed. To access the Guidance Screen, press the Change Page button.

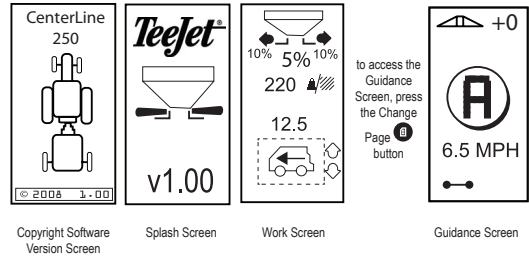

CENTERLINE 250 BBI SYSTEM DIAGRAM

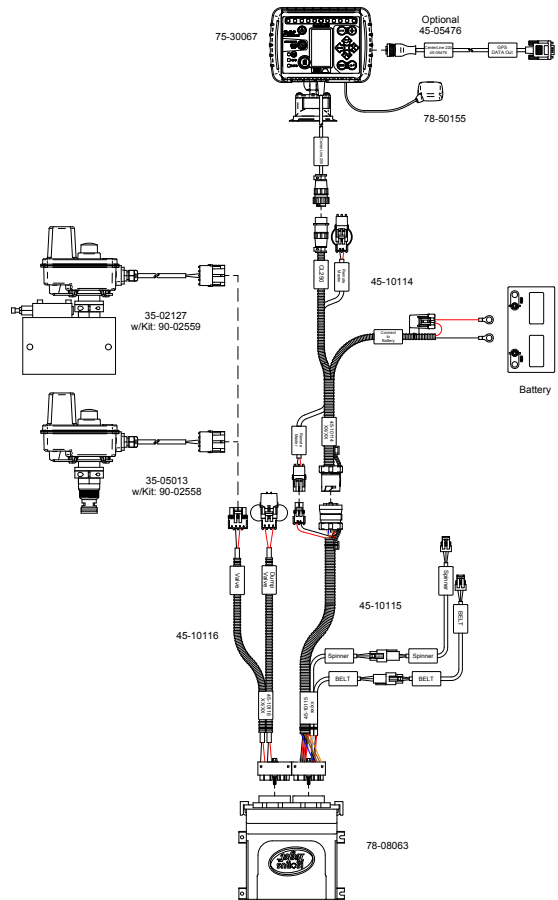



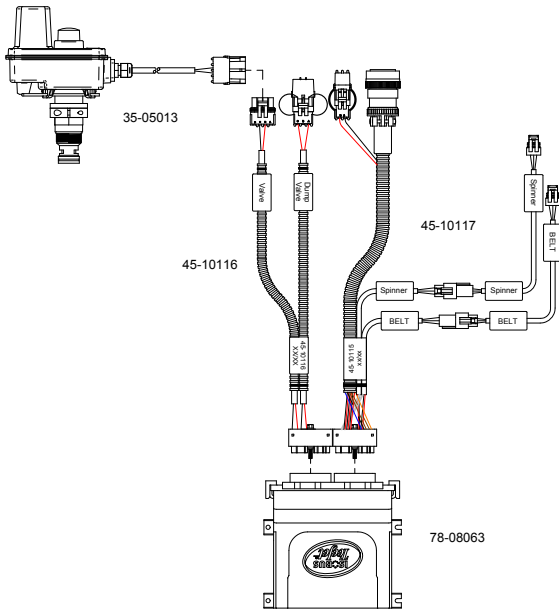





BBI CAN SYSTEM WITH IC18





CHAPTER 2 - IC18 OPERATION SCREENS

SYMBOL OVERVIEW

 Speed	 Spinner RPM
 Applied Area	 Roller RPM
 Applied Amount	 Remaining Hopper Volume
 Application Rate per Minute	 Target Roller RPM

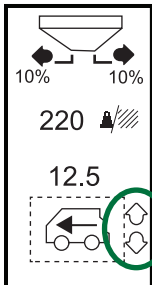
NOTE: Units of measure (U.S., Metric, or GB) are established in Guidance Mode. Refer to Guidance Mode for additional information.



Toggle between the Operation functions by pressing the Arrow Up/Down  buttons.

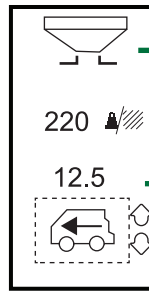

Spreading is inactive

Actual application rate amount/area

Vehicle speed

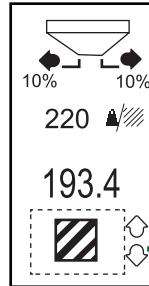

Applied Area

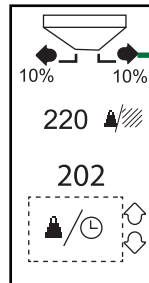

Spreading is active

Application Rate per minute

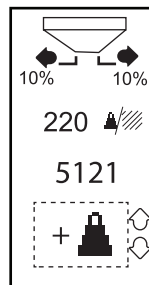

Applied Amount

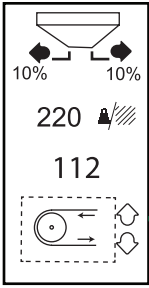

Roller RPM

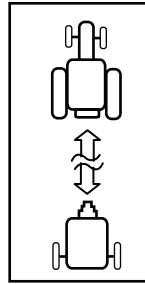

Implement is Disconnected

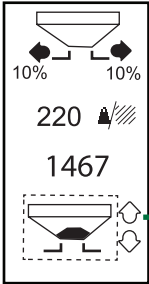

Remaining Hopper Volume

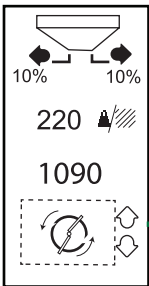

Spinner RPM

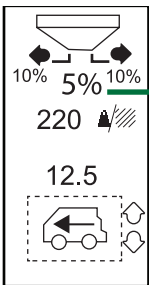

Step % increased by 5%
NOTE: Change in Step % from operation mode is made by pressing the Up/Down buttons.

CHAPTER 3 - IC18 MENU NAVIGATION

STARTUP SEQUENCE

Power up the system by pressing the Power  button.

Upon power up, the CL250 will perform the following:

1. Display copyright and software version screen for four (4) seconds with a black background.
2. Display copyright and software version screen for three (3) seconds with a white background.
3. Display splash screen.
4. Detect if GPS data are present (this occurs simultaneously within the display screen sequence).
5. If an implement controller is added to the system, the Implement Control Screen will be displayed. To access the Guidance Screen, press the Change Page button.

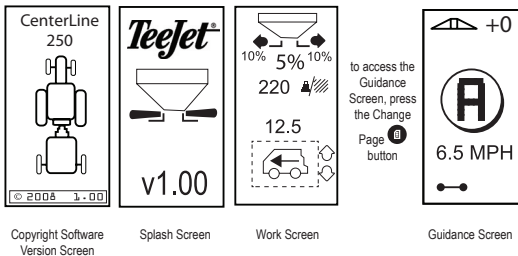

The work screen is the default screen (what the user will view).



Menu structure is displayed in the following flowchart.

NOTE: Some of the functions displayed in the flow charts may or may not be available depending on the implements being used.

USER SETUP

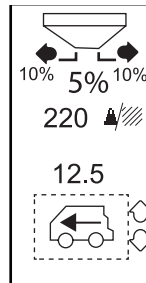



To access User Setup, press the Enter  button.

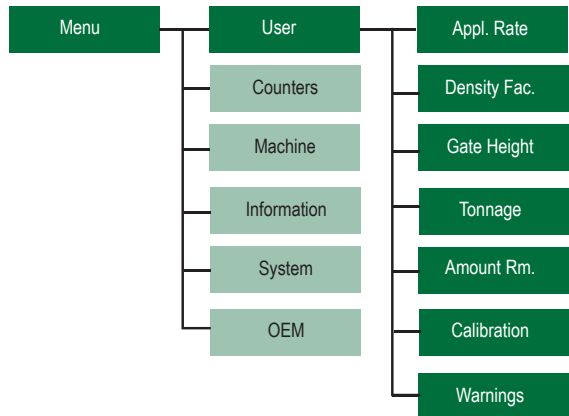
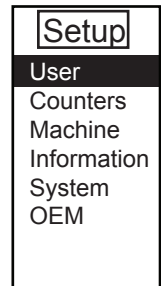

Use the Down Arrow  button to scroll down and select "User". Press the Enter  button to enter User Setup.







Application Rate

Application Rate is used to define the rate of product being applied per acre. To access Application Rate, use the Down Arrow  button to scroll down and select “Application Rate”. Press the Enter  button. Enter the targeted application rate. Application rate is established using the Up/Down  Arrow buttons. Press the Enter  button to save the setting and return to User Setup.

NOTE: If application rate exceeds 8,000 lbs, it will be displayed in decimal tons (up to 10 tons/20,000 lbs).



User Setup	Appl. Rate
Appl. Rate	2000
Density Fac.	lb/ac
Gate Height	Enter
Tonnage	Application
Amount Rm.	Rate
Calibration	
Warnings	

Density Factor

Density Factor is the density of the material being applied. To access Density Factor, use the Up/Down  Arrow buttons to scroll down and select “Density Factor”. Press the Enter  button. Enter the density factor. Please note that different materials have different densities. A new value should be entered for each new product applied. Density Factor is established using the Up/Down  Arrow buttons. Press the Enter  button to save the setting.

User Setup	Density
Appl. Rate	65
Density Fac.	lb/ft3
Gate Height	Enter
Tonnage	Material
Amount Rm.	Density
Calibration	
Warnings	

Gate Height

Gate Height is the height of the rear gate in inches. To access Gate Height, use the Up/Down  Arrow buttons to scroll down and select “Gate Height”. Press the Enter  button.



Enter the gate height. This is the height the gate is open to allow for material flow from the vehicle bed.

NOTE: Gate Height ranges from 1 - 20 inches in .5 inch increments.

User Setup	Gate Height
Appl. Rate	4.0
Density Fac.	in
Gate Height	Enter
Tonnage	Gate
Amount Rm.	Height
Calibration	
Warnings	

Tonnage

Tonnage is used when the application rate exceeds the number of digits allowed on the screen display. This feature converts pounds to tons.



To access Tonnage, use the Up/Down  Arrow buttons to scroll down and select “Tonnage”. Press the Enter  button to toggle between “Off” and “On.” Press the Escape  button to return to User Setup.

User Setup	Tonnage
Appl. Rate	Tons
Density Fac.	off
Gate Height	
Tonnage	
Amount Rm.	
Calibration	
Warnings	

Flow Factor

NOTE: Flow Factor will not be displayed as a programming option unless it is turned on under the OEM menu.



The fertilizer's ability to flow is affected by a number of factors (shape, grain, weight, moisture). These factors may vary with each batch and it may change due to weather (humidity, etc.). In order to accommodate for this, the IC18 uses a flow factor to compensate for the nature of the applied fertilizer.

To access Flow Factor, use the Down Arrow  button to scroll down and select "Flow Factor". Flow Factor is established using the Up/Down  Arrow buttons. Press the Enter  button to save the setting.

User Setup
Appl. Rate
Density Fac.
Gate Height
Tonnage
Flow Factor
Amount Rm.

Flow Fctr.
1.00
Enter
Flow Factor

Amount Remaining

Enter the amount of material remaining in the hopper. To access Amount Remaining, use the Up/Down  Arrow buttons to scroll down and select "Amount Remaining". Press the Enter  button.



User Setup
Appl. Rate
Density Fac.
Gate Height
Tonnage
Amount Rm.
Calibration
Warnings

Amnt. Rm.
12500
lb
Enter
Amount Of
Weight
In Bed



NOTE: When filling, the figure entered must be equal to the total weight of the material loaded in the hopper. If the machine is equipped with a weighing system, the Amount Remaining menu is not available.

Step %

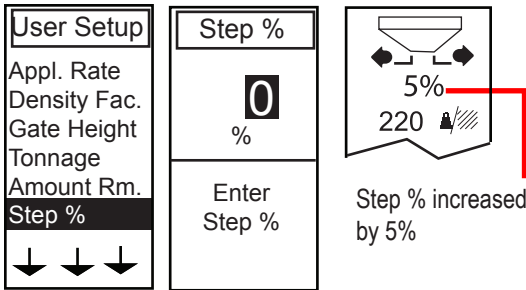

NOTE: Step % will not be displayed as a programming option unless it is turned on under the OEM menu.

Step % is the percent of increase/decrease “boost” of programmed application rate at which the product is being applied. To access Step %, use the Up/Down   Arrow buttons to scroll down and select “Step %”. Press the Enter  button.



NOTE: This percentage can be changed on the Work Screen up or down the preset amount by using the Up/Down   Arrow buttons.

Application Rate Test

Application rate test is used for “fine tuning” the flow factor and to accommodate for the changing factors (conditions, humidity, etc.) occurring throughout the day. This tool enables the operator to monitor the flow factor during the day and/or season. To access Application Rate Test, use the Up/Down   Arrow buttons to scroll down and select “Appl. R. Test.” Press the Enter  button.

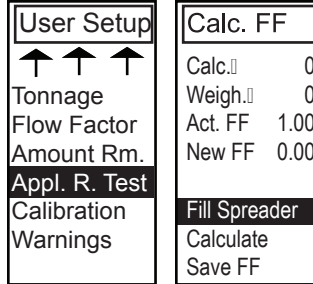









Options for adjustment include “Fill Spreader,” Calculate,” and “Save New FF”.

NOTE: Application Rate Test will only be displayed when Flow Factor is turned on under the OEM menu.

APPLICATION RATE TEST - Spreader Without Weigh System Installed



If a weigh system is not installed, the remaining hopper weight must be entered manually. This is completed once the hopper has been filled and before calculating a new flow factor.



Select "Fill Spreader" using the Up/Down /Down  Arrow buttons. Enter the remaining weight in the hopper and press the Enter  button. Spread a suitable amount of fertilizer in the field. Select "Calculate" and press the Enter  button.

Enter the remaining contents in the hopper using the Up/Down /Down  Arrow buttons. The controller will calculate a new flow factor (displayed as "New ff"). Once an appropriate flow factor has been calculated, use the Up/Down /Down  Arrow buttons to select "Save New ff." Press the Enter  button. The new flow factor will be saved and will be displayed in the Actual FF (Flow Factor) line on the display.

Calc. FF	Amnt. Rm.
Calc.[] 0	100  lb
Weigh.[] 0	
Act. FF 1.00	Enter Amount Of Weight In Bed
New FF 0.00	
Fill Spreader	
Calculate	
Save FF	



APPLICATION RATE TEST - Spreader With Weigh System Installed

If a weigh system is installed, nothing needs to be entered. The weighing system will make the necessary calculations. The first line "Calc" will display the theoretical amount/area calculated via the position of the actuator. The second line "Weigh" will display the amount/area calculated via the weight system. These two figures are used to calculate the new flow factor. Spread a suitable amount of fertilizer in the field. Select "Fill Spreader" using the Up/Down /Down  Arrow buttons. Select "Calculate" and press the Enter  button. The controller will calculate a new flow factor (displayed as "New FF")."



Once an appropriate flow factor has been calculated, use the Up/Down /Down  Arrow buttons to select "Save New FF." Press the Enter  button. The new flow factor will be saved and will be displayed in the Actual FF (Flow Factor) line on the display.

Calc. FF	Amnt. Rm.
Calc.[] 0	0  lb
Weigh.[] 0	
Act. FF 1.00	Enter Amount Of Weight In Bed
New FF 0.00	
Fill Spreader	
Calculate	
Save FF	

Calibration

Each type of spreader has a variety of variables that factor into the calibration process (roller diameter, gate height and width, sensor type, type of belt or chain, etc.). The calibration number factors these variables into the spreader output. To access Calibration, use the Down Arrow  button to scroll down and select "Calibration". Press the Enter  button.

User Setup	Calibration
Appl. Rate	Actual calib: 0.0
Density Fac.	
Gate Height	
Tonnage	
Amount Rm.	
Calibration	Edit Cal. Val
Warnings	Start Calib.

NOTE: To manually enter a calibration number, select "Edit Cal Val" and enter the number using the Up/Down   Arrow buttons, followed by the Enter  button.







Calib. Val.
0.0
Enter The Calibration Number

WARNING: This Calibration procedure requires that the spreader output calibration be performed using the "Reference Gate Height". The default gate height is 4.0 inches. The actual gate height used on the spreader and the Reference Gate Height must be the same. Performing a calibration using an actual gate height that is different than





the Reference Gate Height will result in incorrect calibration and may cause product to be misapplied. Please consult your BBI dealer for instructions on changing the Reference Gate Height to a different value.

CALIBRATION - Start Calibration







NOTE: Material will be dispensed during this procedure. Be sure that a collection device is in place so that a proper weight can be determined.

The Start Calibration function automatically calculates the number of sensor pulses per cubic foot of material dispensed. To access Start Calibration, use the Down Arrow  button to scroll down and select "Start Calib.". Press the Enter  button. Use the Up/Down   Arrow buttons to enter the density of material being used for calibration and press the Enter  button. Press the Escape  button to return to Calibration screen.

Calibration	Density	
Actual calib: 0.0	65 lb/ft3	
Edit Cal. Val Start Calib.	Enter Material Density	Press Start/Stop To Start Calibration



Press the Start/Stop Application  button to begin the calibration process. **Material will be dispensed at this time.** Once the calibration process is complete, press the Start/Stop Application  button. Weigh the dispensed material and enter the weight on the Calib. Weig. screen using the Up/Down  Arrow buttons. Press the Enter  button. The actual Calibration number will be saved and displayed. Press the Escape  button to return to User Setup screen.

WARNINGS - Amount Remaining

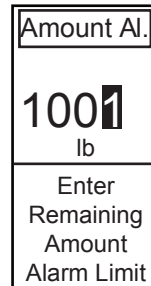
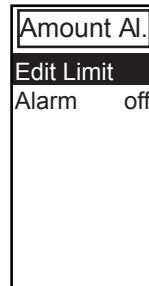
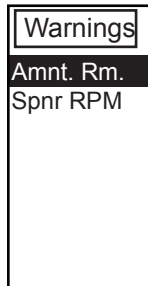
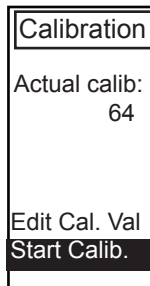
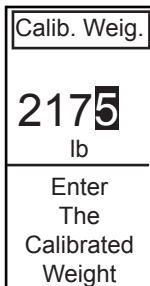
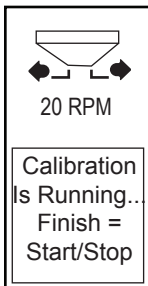
The Amount Remaining Warning alerts the operator when the amount of material in the hopper reaches the entered level. Use the Down Arrow  button to scroll down and select "Edit Limit". Press the Enter  button. Use the Up/Down  Arrow buttons to enter the alarm unit number and press the Enter  button. Use the Enter  button to toggle the Alarm either "On" or "Off". Press the Escape  button to return to Amount Remaining.







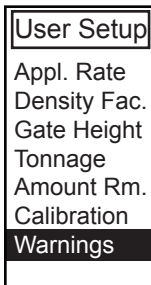

Warnings

Warnings are customized and can be selected for user preference. The two options available include Amount Remaining and Spinner RPM. To access Warnings, use the Up/Down  Arrow buttons to scroll down and select "Warnings". Press the Enter  button.



WARNINGS - Spinner RPM

The Spinner RPM alerts the operator when no pulses are being received. The entered value indicates the LOW limit. If the actual spinner RPM falls below the stated value, the alarm will sound and the error message will be displayed: Spnr RPM is Low.

Use the Down Arrow  button to scroll down and select "Edit Limit". Press the Enter  button. Use the Up/Down   Arrow buttons to enter the alarm unit number and press the Enter  button. Use the Enter  button to toggle the Alarm either "On" or "Off". Press the Escape  button to return to Spnr RPM.

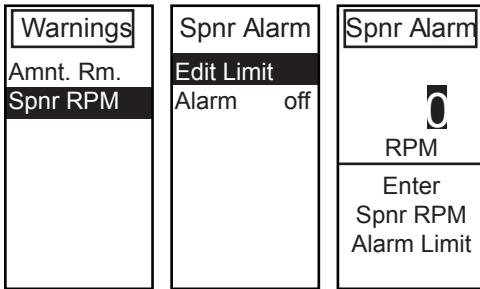

SYSTEM ALARMS

In addition to the selectable warnings, the IC18 Job Computer contains general system alarms that are described as follows.

IMPORTANT! The reason for any warnings should be checked thoroughly before cancelling the alarm!

To cancel an alarm warning, press the Escape  button. The alarm will resound every 10 seconds if the condition causing the alarm has not been remedied.

Application Start Is Not Possible

This alarm will appear if an application is attempted from a screen other than the Work Screen (Operation Mode).



Amount Remaining Is Low

This alarm will appear if the hopper amount has reached the low limit level entered.

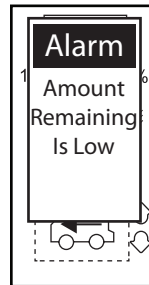

Regulating Outside Of Application Rate

This alarm will appear if the target rate cannot be achieved. If the actual rate is below target rate, reduce ground speed or select a higher gate height. If the actual rate is higher than the target rate, service may be required. Please contact your authorized BBI dealer.

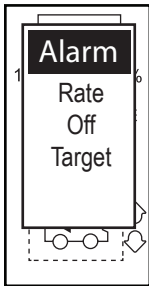

No CAN Speed Available

This alarm will appear when the IC18 Job Computer is running with CAN speed and a valid speed signal is not available on the CAN bus. If GPS is temporarily lost (e.g., when driving under trees or if the vehicle is parked under a roof).

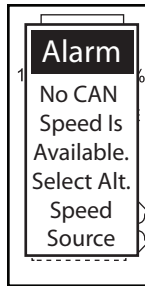

Spinner RPM Too Low

This alarm will appear if the spinner RPM falls below the low limit level entered.

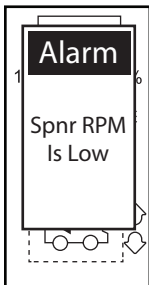

No Memory Left

This alarm will appear if the file system does not have enough remaining memory to save counter data. Delete files on the IC18 job computer to free up memory.

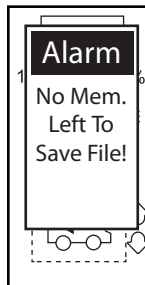

Minimum Hydraulic Motor RPM Cannot Be Reached

Reached

This alarm will appear if the minimum hydraulic motor RPM cannot be reached (during hydraulic calibration).

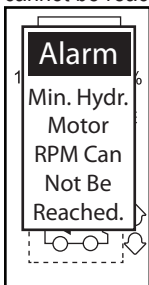

File Saving Failed

This alarm will appear if file saving fails when counters are being saved.

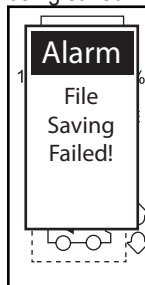

Simulated Speed Is Active

This alarm will appear if simulated speed is activated when the system powers up.

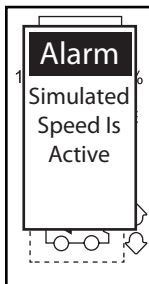

Stop Spreading

This alarm will appear if certain menus are accessed during the spreading process (e.g., in the calibration option).

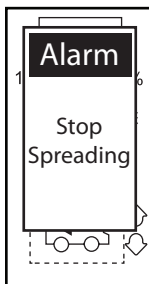

SYSTEM COUNTERS

Counters are used by the system to allow the operator to see the status of various system components.

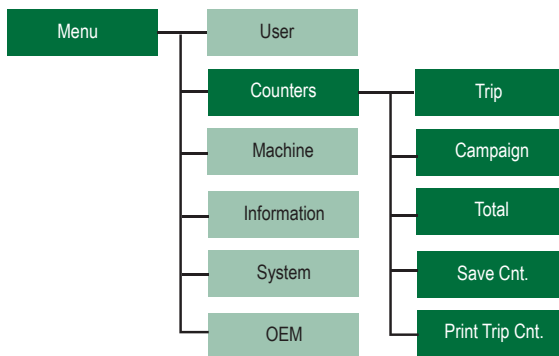

Trip

TRIP - View Trip

This counter allows for the selection of “View Trip,” “Select Trip,” and “Delete Trip.” The trip counter can save information on up to ten (10) trips made. The active counter number will be displayed in the menu heading. Use the Up/Down Arrow buttons to scroll down and select “View Trip”. Press the Enter button to select.

Counters
Trip
Campaign
Total
Save Cnt.
Print Trip Cnt

Trip 1/10
View Trip
Select Trip
Delete Trip

Trip 1/10	
ton(long)	29.10
ac	8.25
mile	1.70
Time	0:12

TRIP - Select Trip

Select Trip is used to display the different trip counters (numbered 1-10) that were saved on the console. The active counter number will be displayed in the menu headline. Use the Up/Down Arrow buttons to scroll to the desired Trip number. Press the Enter button to select.

Trip 1/10	Trip Cnt.
View Trip	Trip Cnt. 1
Select Trip	Trip Cnt. 2
Delete Trip	Trip Cnt. 3
	Trip Cnt. 4
	Trip Cnt. 5
	Trip Cnt. 6
	↓ ↓ ↓

TRIP - Delete Count

Select the trip counter to be deleted using this option. Use the Up/Down Arrow buttons to scroll to the desired Trip number. Press the Enter button to select. A delete warning will be displayed to ensure confirmation. Pressing the Enter button will confirm the deletion of the Trip. Press the Escape button to cancel the deletion.

Trip 1/10	Trip 1/10
View Trip	Warn.
Select Trip	Del. cnt.?
Delete Trip	Enter=yes
	Esc = no
	Time
	0:12

Campaign

The Campaign function provides the total for the entire season. Data is constantly added to the campaign counter during operations. Use the Up/Down Arrow buttons to scroll to the desired option. Press the Enter button to select.

Counters
Trip
Campaign
Total
Save Cnt.
Print Trip Cnt

CAMPAIGN - View

View Campaign allows the operator to view the amounts, area, and time that have been accumulated to date.

Campaign	Campaign
View Cnt.	lb
Delete Cnt.	172
	ac
	0.65
	Time
	0:01

CAMPAIGN - Delete

Use the Up/Down   Arrow buttons to scroll to "Delete Cnt". Press the Enter  button to select.

A delete warning will be displayed to ensure confirmation. Pressing the Enter  button will confirm the deletion of the Trip. Press the Escape  button to cancel the deletion.

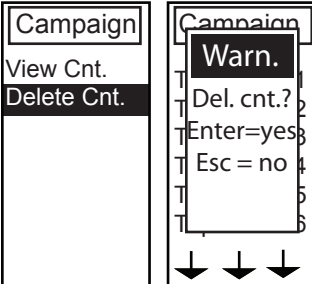





Total

The Total Counters menu provides information regarding the total work performed by the spreader during its service life. This information cannot be edited.

Counters	Total Cnt.
Trip	lb
Campaign	172
Total	ac
Save Cnt.	0.65
Print Trip Cnt	Time
	0:01

Save Counters

NOTE: An optional cable is required to connect the CenterLine 250 to a computer to save Trip and Total Counter values to a file. Contact your local BBI dealer for additional information.

Save Counters can be used to save Trip and Total Counter values to a file in HTML or CSV file formats. HTML file formats can be viewed in an Internet browser. CSV file formats can be viewed in Microsoft Excel. Use the Up/Down   Arrow buttons to scroll to "HTML file" or "CSV file." Press the Enter  button to select. Press the Escape  button to cancel.

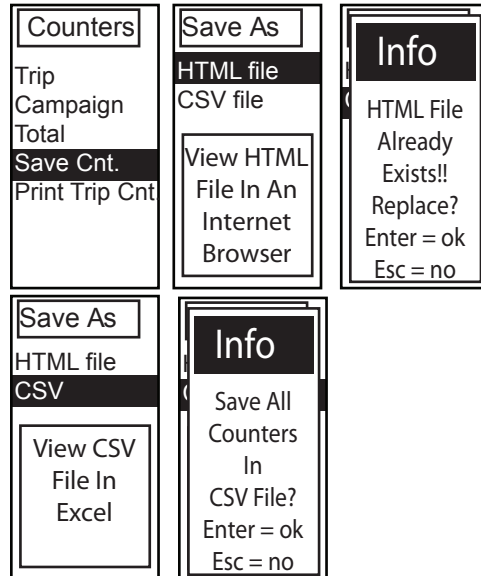

Print Trip Counters

NOTE: An optional cable is required to connect the CenterLine 250 to a computer to print the saved trip/campaign files. Contact your local BBI dealer for additional information.

Print Trip Counters can be used to print the selected Trip Counter values based on a date range. Use the Up/Down Arrow buttons to scroll to “Edit Date” and press the Enter button to select. Use the Up/Down Arrow buttons to enter a date range, followed by the Enter button. Use the Up/Down Arrow buttons to scroll to “Print trip” and select either “Active trip” or “All trip counters”. Press the Enter button to select.

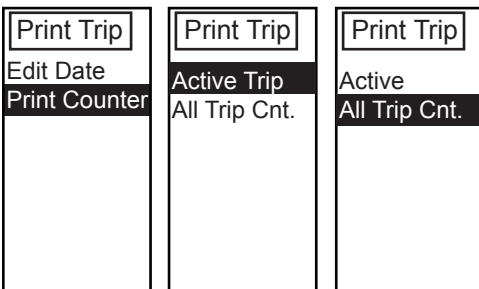
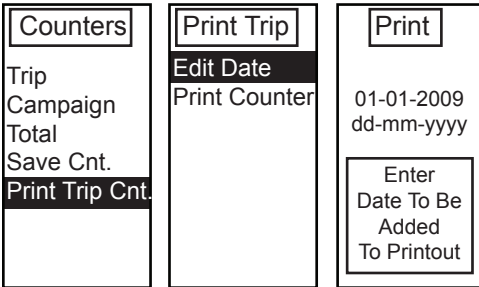

MACHINE

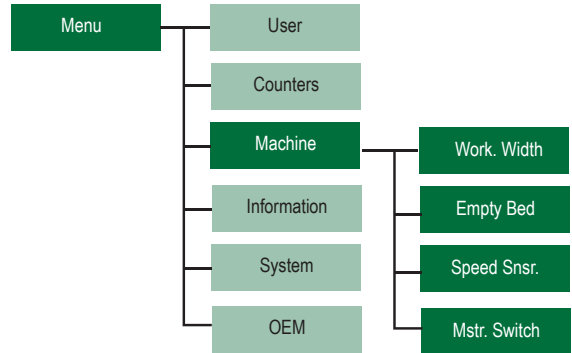

Machine Setup

To access Machine Setup, use the Up/Down Arrow buttons to scroll to “Machine”. Press the Enter button.

NOTE: Work Width is the Application Width used to regulate the output of the spreader. This value does not program the Guidance Width used by the CenterLine 250 lightbar. See Chapter 5 for Guidance Swath Width setup. Typically, both the Guidance Width and the Application (Work) Width should be the same value.

WARNING: Steering the vehicle and spreader on a different swath distance than the programmed Work Width of the spreader may result in severe misapplication of product applied.

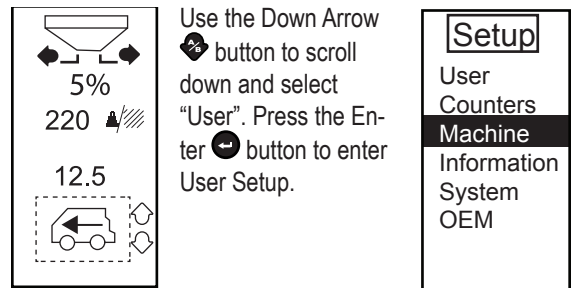

Work Width

To access Work Width, use the Up/Down Arrow buttons to scroll down and select “Work Width”. Press the Enter button. Enter the actual working width. The width is established using the Up/Down Arrow buttons. Press the Enter button to save the setting and return to Machine Setup.



Empty Bed

Empty Bed is used to allow the operator to quickly empty the remaining load. To access the Empty Bed option, use the Up/Down Arrow buttons to scroll down and select “Empty Bed”. Press the Enter button. The Empty Bed option allows the hopper to be emptied by pressing the Start/Stop Application button to start the belt. Once the hopper is emptied, press the Start/Stop Application button to stop the belt again.

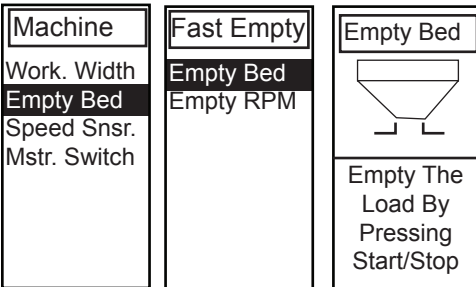

Empty RPM

Empty RPM is the revolutions per minute used to drive the belt during the Empty Bed operation. To access Empty RPM, use the Up/Down Arrow buttons to scroll down and select “Empty RPM.” Press the Enter button.

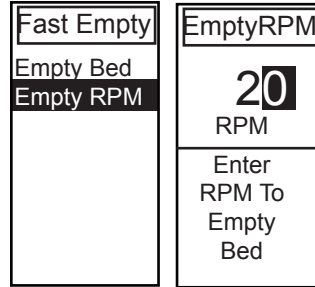

Speed Sensors

Speed Sensors are used to input ground speed. Options include Sensor, Simulator, and CAN. Selecting “Sensor” will allow for the configuration of pulses per 300 feet. Selecting “Simulator” will allow for simulated speed to be entered using the “Edit Value” option. Selecting “CAN” allows for GPS speed to be used. Use the Up/Down Arrow buttons to scroll down and select “Speed Sens.” Press the Enter button.

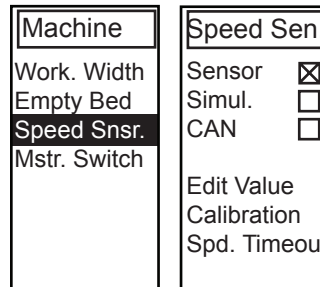

NOTE: The spreader belt will be running during this process. It is important to keep a safe distance away from the machine to avoid personal injury.

SPEED SENSORS - Edit Value

When "Sensor" is checked, the Edit Value is used to enter/edit the number of pulses per 300 ft. When "Simulator" is checked, the edit value is used to enter/edit the desired speed in MPH.

When "CAN" is checked, this option is not available.

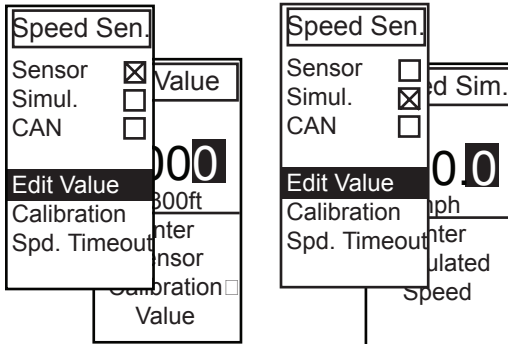

SPEED SENSORS - Calibration

When "Sensor" is checked, "Calibration" is used to calculate the number of speed sensor pulses accumulated in a 300 feet distance. When "Simulator" or "CAN" are checked, this option is not available.

To properly calibrate the speed sensor, accurately measure a 300 feet driving distance and clearly mark the starting and ending points. Prior to selecting "Calibration," position the vehicle at the start point of the measured distance. Using the Up/Down Arrow buttons, select "Calibration." Starting from a complete stop, drive the 300 feet distance. During this process, the Pulses counter will accumulate sensor pulses. At the end of the measured distance, press the Enter button. This will store the number of sensor pulses per 300 feet of travel and complete the speed sensor calibration process.

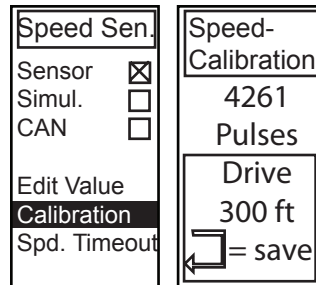







Speed Timeout

This option is only available when “CAN” speed sensor is checked. Speed Timeout allows the console to use the last known ground speed value for a period of time in the event there is a temporary loss of GPS speed signal. Enter the time allowed in seconds for the speed timeout. The last registered speed will be used to regulate the output of the spreader for this programmed period of time. If GPS speed signal is obtained before the timeout, product rate control will resume based on actual ground speed. If GPS speed signal is not obtained before the speed timeout expires, ground speed will drop to zero, the No CAN Speed alarm will appear, and automatic rate control will not be possible.

Speed Sen.	Timeout
Sensor <input type="checkbox"/>	
Simul. <input type="checkbox"/>	
CAN <input checked="" type="checkbox"/>	4
	Seconds
Edit Value	Time Betw.
Calibration	loss of CAN
Spd. Timeout	Speed And
	Speed = 0

Master Switch

Master Switch is used to allow the operator to choose between a “remote master” switch or the Start/Stop Application  button. Use the Up/Down   Arrow buttons to scroll down and select the desired option. Press the Enter  button to toggle the check box feature. To use the Start/Stop Application  button, select “Console”. To use a remote master switch, select “Remote.” Press the Escape  button to return to the System Setup menu.

Machine	Mstr. Switch	Mstr. Switch
Work. Width	Console <input checked="" type="checkbox"/>	Console <input type="checkbox"/>
Empty Bed	Remote <input type="checkbox"/>	Remote <input checked="" type="checkbox"/>
Speed Snsr.		
Mstr. Switch		

INFORMATION

The Information screen displays the settings that have been entered into the IC18 Job Computer. Information on this screen cannot be edited; it is for viewing purposes only.

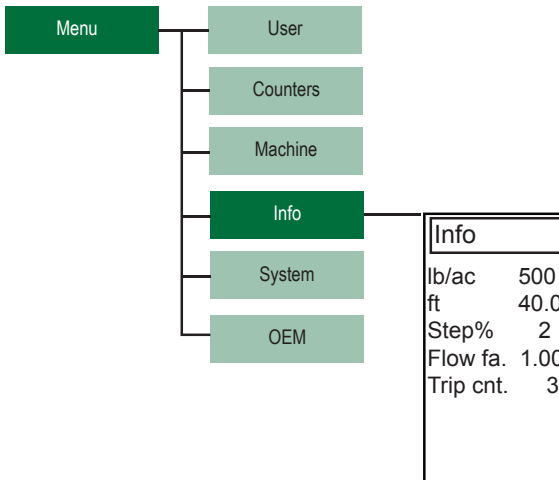

AMOUNT/AREA: displays the application rate
 WORKING WIDTH: displays the working width
 STEP%: displays the current step %
 FLOW FACTOR: displays the flow factor
 TRIP COUNTER: displays the counter number

SYSTEM

System Setup is used to adjust and monitor system settings.

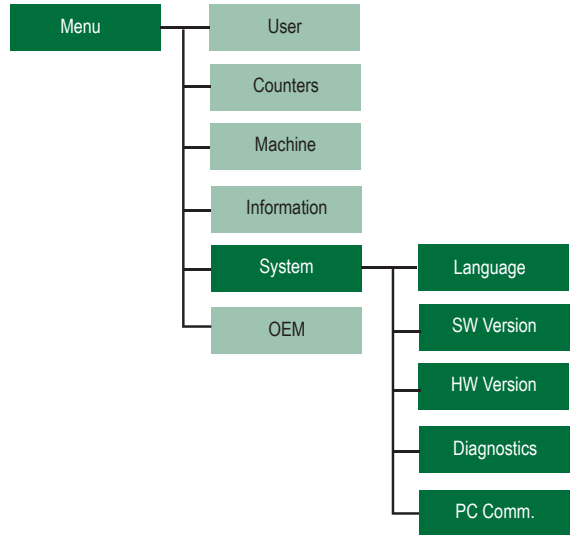



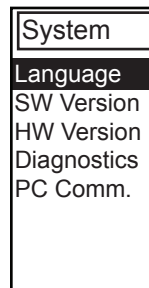

Language

The language displayed on the console is selected using this menu. To access the Language option, use the Up/Down Arrow buttons to scroll down and select "Language". Press the Enter button. If no language files are loaded, the screen will be empty. The default language of English will be used. Press the Escape button to return to the System Setup menu.







Software Version

The software program version and the latest build number are displayed on this screen. This information may be of use if Technical Support is required. Information on this screen is available for viewing purposes only. To access the Software Version option, use the Up/Down   Arrow buttons to scroll down and select "SW version". Press the Enter  button. Press the Escape  button to return to the System Setup menu.

System	SW Version
Language	Version:
SW Version	1.02
HW Version	Build:
Diagnostics	00174(JS)
PC Comm.	





Hardware Version

The hardware version is displayed on this screen. This information may be of use if Technical Support is required. Information on this screen is available for viewing purposes only. To access the Hardware Version option, use the Up/Down   Arrow buttons to scroll down and select "HW version". Press the Enter  button. Press the Escape  button to return to the System Setup menu.

System	HW. Info
Language	CPU. Ver.
SW Version	30
HW Version	IO. Cat.
Diagnostics	1
PC Comm.	IO. Type.
	2
	IO. Ver.
	2





Diagnostics

NOTE: Diagnostics is used for troubleshooting input/output of the controller (sensor or actuator). These menus are typically accessed only upon Customer Service personnel request.

To access the Diagnostics option, use the Up/Down   Arrow buttons to scroll down and select "Diagnostics". Press the Enter  button. Press the Escape  button to return to the System Setup menu.

System
Language
SW Version
HW Version
Diagnostics
PC Comm.

Diagnostics - Test Input

Test Input displays the input high and low values for weighing, Spinner RPM, hydraulic motor, and speed (for diagnostic purposes only). To access the Test Input option, use the Up/Down   Arrow buttons to scroll down and select "Input". Press the Enter  button. Press the Escape  button to return to the Diagnostics menu.

Test	Test Input
Input	Weighing
Output	LO 0
	Spnr RPM
	LO 535
	Hydr. Motor
	HI 0
	↓ ↓ ↓

Diagnostics - Test Output

Test Output is used to test the regulating valve at different percentages of duty cycle. To access the Test Output option, use the Up/Down Arrow buttons to scroll down and select "Output". Press the Enter button. Press the Escape button to return to the Diagnostics menu.

Test
Input
Output

Diagnostics - Test Output - Reg. PWM

Regulating PWM is used to change the percentage of duty cycle. To access the Regulating PWM option, use the Up/Down Arrow buttons to scroll down and select "Reg. PWM". Use the Up/Down Arrow buttons to enter the percent dutycycle and press the Enter button. Press the Escape button to return to the Diagnostics menu.

Test output
Reg.PWM 0%
Reg. DIR Off
Dump Out Off

Test PWM
% Dutycycle
Enter Test Dutycycle

Diagnostics Test Output - Reg. DIR

This setting is used to test the percent duty cycle (as input during the Reg. PWM test) on the regulating valve open and closed (on/off). This setting can be toggled using the Enter button to either "On" or "Off."

Test output
Reg.PWM 0%
Reg. DIR Off
Dump out Off

Diagnostics Test Output - Dump Out





This setting is used to test if the dump valve opens and closes (on/off). This setting can be toggled using the Enter button to either "On" or "Off."

Test output
Reg.PWM 0%
Reg. DIR Off
Dump out Off

PC Communication

NOTE: An optional cable is required to connect the IC18 Job Computer to a computer for data transfer. Contact your local BBI dealer for additional information.

The IC18 Job Computer is equipped with a serial connection that can communicate with a PC (used for file transfer). Data transfer is performed with dedicated PC tools. In order to enable the IC18 Job Computer to communicate with the PC, the controller must be left in this menu. The PC will not be able to communicate with the IC18 Job Computer if this screen is not displayed.

To access the PC Communication option, use the Up/Down   Arrow buttons to scroll down and select "PC Comm.". Press the Enter  button. Press the Escape  button to return to the System menu.

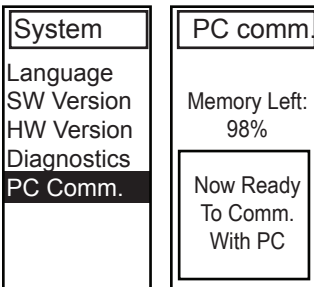

CHAPTER 4 - CENTERLINE® 250 OVERVIEW

The CenterLine® 250 provides straight and curved A-B guidance and implement control with a simple interface. Implement control is an add-on feature through an ISO-BUS compatible job computer (e.g., the IC18 Job Computer).

The CenterLine 250 provides the following features:

- Versatile GPS Guidance in a compact, portable package.
- LED Lightbar guidance plus a graphical display for complete guidance information.
- High-quality, 5 Hz internal GPS engine with external antenna.
- Simple setup gets you up and running in no time.
- Straight-line (parallel) and curved A-B guidance modes.
- Integrated look-ahead functionality anticipates vehicle's future position.
- Return-to-point feature.
- Durable, sealed rubber keypad is easy to see and provides good tactile feedback.
- Provides RADAR-like speed signal output for use with other control systems that require a ground speed signal.

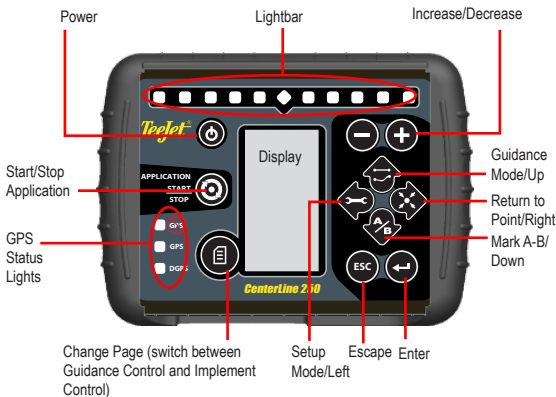

CENTERLINE 250 - SETUP

Mount the magnetic antenna on the roof of the vehicle. The antenna must be mounted in the center of the guidance swath. If the vehicle is non-metallic, attach the metal mounting plate via the adhesive strips. Place the antenna on the metal plate.

Avoid mounting the antenna close to other electrical installations (air conditioning equipment, radio antennas, etc.). Avoid coiling excess antenna cable - configure it in a "figure 8" shape and keep the cable at least 1.5 feet from possible sources of electrical interference.

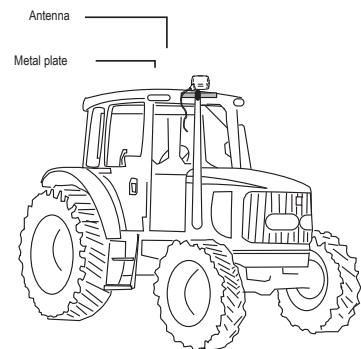
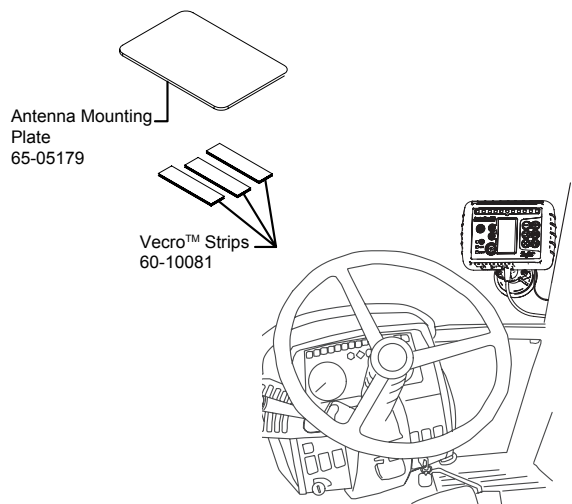

CHAPTER 5 - CENTERLINE® 250 START UP

Power up the system by pressing the Power  button.

Power down the system by pressing and holding the Power  button for approximately four (4) seconds.

Upon power up, the CL250 will perform the following:

1. Display copyright and software version screen for four (4) seconds with a black background.
2. Display copyright and software version screen for three (3) seconds with a white background.
3. Display splash screen.
4. Detect if GPS data are present (this occurs simultaneously within the display screen sequence).
5. If an implement controller is added to the system, the Implement Control Screen will be displayed. To access the Guidance Screen, press the Change Page button.

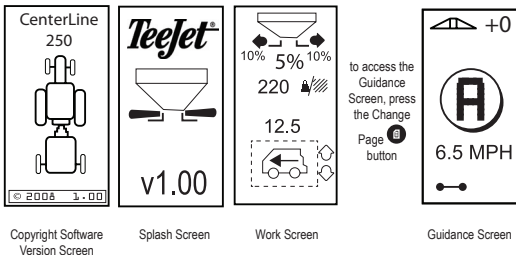

NOTE: Please refer to the IC18 Job Computer User Guide for further instructions.

GPS STATUS LIGHTS







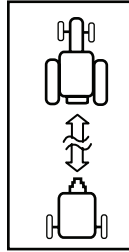

IMPLEMENT DISCONNECTED

If the implement controller view is selected when no implement is connected, this screen will be displayed. If the implement is disconnected, the CL250 will automatically change to this screen.



CENTERLINE 250 SETUP MODE

In order to enter Setup Mode, the view must be set to "Guidance". Make sure the unit is in Guidance Mode by pressing the Change Page  button. Press the Setup  button to enter into Setup Mode. The Escape  button is used to exit without saving changes. The Up/Down   Arrow buttons navigate through the setup options. The Enter  button selects the setup page and parameters.

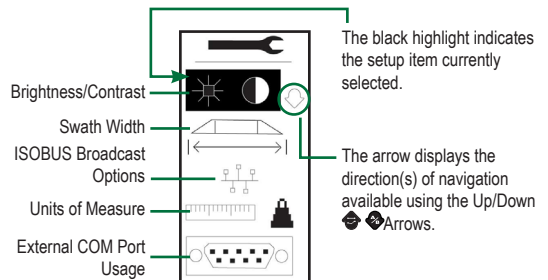

NOTE: Delay start for 90 seconds after DGPS LED turns green.

BRIGHTNESS AND CONTRAST

With the Brightness and Contrast option highlighted, press the Enter button to enter into Brightness and Contrast setup. The Plus or Minus buttons increase or decrease the brightness levels. The Up/Down Arrow buttons increase or decrease contrast levels. The Left and Right Arrow buttons invert the screen colors. Press the Enter button to save the changes and return to the Guidance Screen.

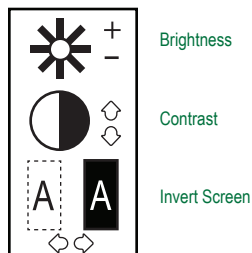

SWATH WIDTH

Highlight the Swath Width option and press the Enter button to enter into Swath Width Setup. Choose the source of the swath width (the highlighted area indicates the current selection). Guidance width is stored in the CenterLine 250. The application width is transferred from the implement controller. Application width is the maximum working width of the implement (it does not change if sections are switched on or off).

If the application width is unknown, either because no implement is connected or the implement does not transmit width, the value will be blanked and the guidance width will be used even if the application width is selected. The active swath width always indicates the width used by guidance.

If the application width is selected and the implement is disconnected, the active swath width will be set to the guidance width, regardless of the screen displayed. This

will cause the A-B line to be discarded and the Guidance view will change to the Mark A Screen.

Use the Plus and Minus buttons to increase or decrease the swath width. Use the Up Arrow button to select the guidance width. Use the Down Arrow button to select the Application Width. Press the Enter button to save the changes and return to the Guidance Screen.

NOTE: Only the Guidance Width can be programmed [insert +/- symbol] in the Guidance Setup mode. The Application Width is the working swath width programmed in Machine Setup and is used to regulate the output of the spreader. Typically, both the Guidance Width and the Application Width should be the same value.

WARNING: Steering the vehicle and spreader on a different swath distance than the programmed Working Width of the spreader may result in severe misapplication of product applied.

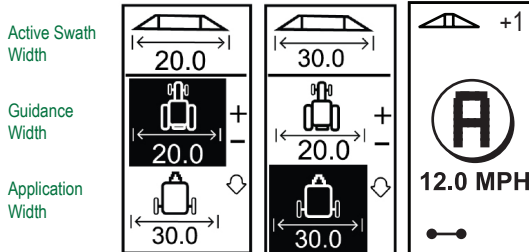

ISOBUS BROADCAST OPTIONS

Enter into the ISOBUS Broadcast Setup mode by highlighting the ISOBUS Broadcast option and pressing the Enter button. The CenterLine 250 can broadcast the speed information in a standard ISO113783 CAN-protocol. This will allow any unit on the ISOBUS to use the speed information from the CenterLine 250.

NOTE: If the tractor is equipped with a Tractor ECU, the CenterLine 250 speed broadcast should be disabled to avoid confusion.

The CenterLine 250 can broadcast position data from the GPS receiver. This is sent in standard NMEA 2000 protocol. Function Instances is used when the CenterLine 250 identifies itself to the ISOBUS. The value is not critical, but if multiple CenterLine 250's are present on the same BUS, it is a good idea to make sure they are using different Function Instances.

Use the Plus and Minus buttons to increase or decrease the Function Instance. Use the Up/Down Arrow buttons to select the broadcast mode. Press the Enter button to save the changes and return to the Guidance Screen.

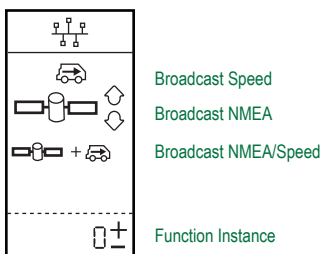

UNITS OF MEASURE



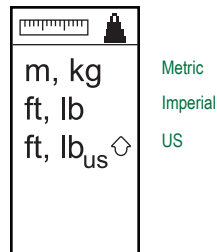

Enter into the Units of Measure mode by highlighting the Units of Measure option and pressing the Enter button. The implement controller may request the Units of Measure and use the same units for implement values. Use the Plus and Minus buttons to select the Units of Measure. Press the Enter button to save the changes and return to the Guidance Screen.



EXTERNAL COM PORT

Enter into the External COM Port mode by highlighting the External COM Port option and pressing the Enter  button. The operator can select the usage of the external COM port. The baud rate is fixed for the auto steering. NMEA echo causes the CenterLine 250 to echo all NMEA data from the internal GPS receiver to the external COM port.

The Implement controller COM port allows the implement controller to connect to an external device via the external COM port on the CenterLine 250. When the COM port is set to “not used,” it is used for debug information which can be monitored via a program on the PC (i.e., Hyperterminal).

Use the Plus and Minus  buttons to increase or decrease the baud rate. Use the Up/Down   Arrow buttons to select the external COM port usage. Press the Enter  button to save the changes and return to the Guidance Screen.

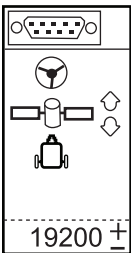

Auto Steering

NMEA Echo

Implement Controller COM Port

Not Used

Baud Rate

CHAPTER 6 - CENTERLINE® 250 - GUIDANCE OPERATIONS

Power up the system by pressing the Power button.

Power down the system by pressing and holding the Power button for approximately four (4) seconds.

Upon power up, the CL250 will perform the following:

- Display copyright and software version screen for four (4) seconds with a black background.
- Display copyright and software version screen for three (3) seconds with a white background.
- Display splash screen.
- Detect if GPS data are present (this occurs simultaneously within the display screen sequence).
- If an implement controller is added to the system, the Implement Control Screen will be displayed. To access the Guidance Screen, press the Change Page button.

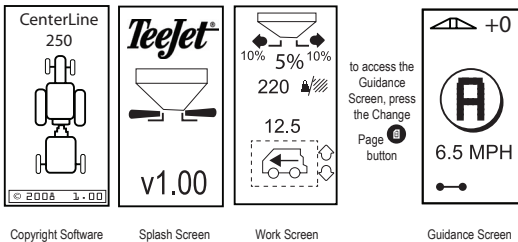

Copyright Software Version Screen

Splash Screen

Work Screen

Guidance Screen

NOTE: Please refer to the IC18 Job Computer User Guide for further instructions.

GPS STATUS LIGHTS



No GPS Signal is available

GPS is detected

DGPS is detected

REFERENCE SCREENS

NOTE: The implement screens below will be displayed in an IC18 Job Computer is connected.

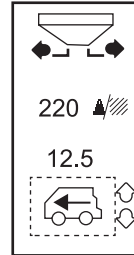

Implement Control Screen for Drop Spreader

GUIDANCE SCREEN - MARK A-B

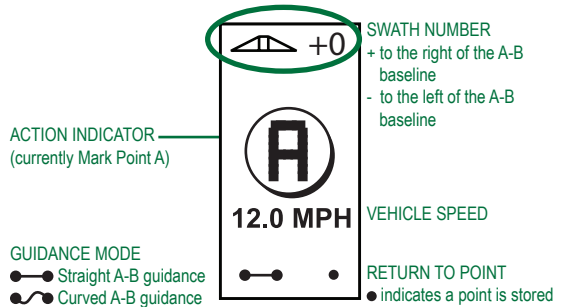

ACTION INDICATOR (currently Mark Point A)

GUIDANCE MODE
 Straight A-B guidance
 Curved A-B guidance

SWATH NUMBER
 + to the right of the A-B baseline
 - to the left of the A-B baseline

VEHICLE SPEED

RETURN TO POINT
 indicates a point is stored

NOTE: Delay start for 90 seconds after DGPS LED turns green.

OPERATION

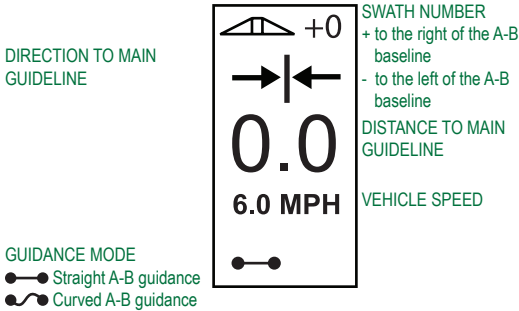

OPERATION FUNCTION KEYS

There are several functions that can be performed during operation. Most of these functions are initiated by the four arrow keys located on the keypad.

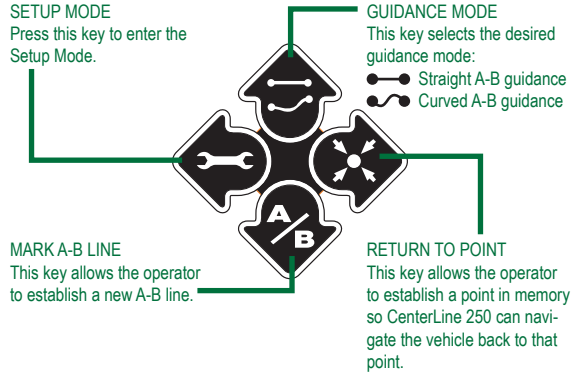

GUIDANCE SCREEN (NAVIGATION VIEW)

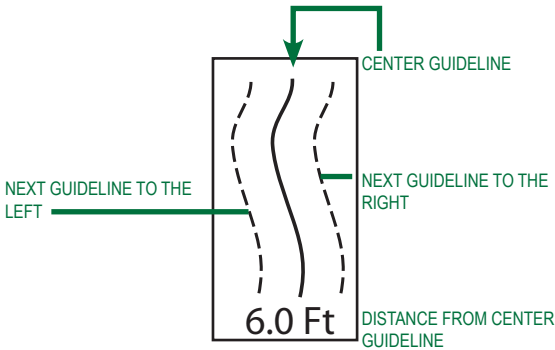

GUIDANCE OPERATION - MODES

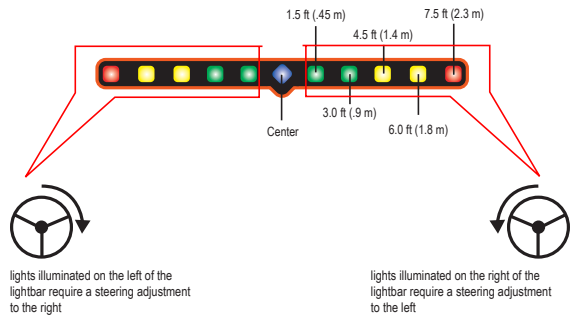

Guidance capabilities include Straight A-B and Curved A-B guidance.



STRAIGHT A-B GUIDANCE

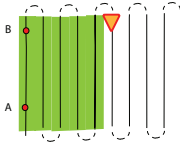

Straight A-B guidance provides straight line guidance based on a reference (A-B) line. The original A-B line is used to calculate all other parallel guidelines.

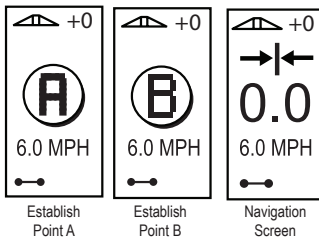

1. Press the Guidance Mode  button to select Straight A-B mode.
2. Drive to the desired location of Point A. While the vehicle is in motion, press the Mark A-B  button to establish Point A. "Point B" will be displayed on the screen. Drive to the location of Point B and press the Mark A-B  button again to establish the A-B line. The CenterLine 250 will immediately begin providing navigation information with the lightbar and Navigation screen.



NOTE: If the CenterLine 250 screen changes to Guidance Mode instead of Mark B, the CenterLine 250 is out of memory. Cycle the power to clear the memory and restart the process.

3. Press the Change Page  button to view the Guidance and Application Control screens. During Guidance view, press the Enter  button to enter the Guidance View (Navigation View).

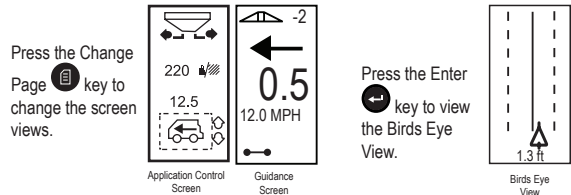

CURVED A-B GUIDANCE

Curved A-B guidance is similar to Straight A-B Guidance except that the reference line is curved.

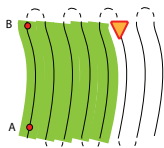

NOTE: Curved Guidance is recommended not to exceed 30° within the A-B Guideline.

1. Press the Guidance Mode button to select Curved A-B guidance.
2. Drive to the desired location of Point A. While the vehicle is in motion, press the Mark A-B button to establish Point A. "Point B" will be displayed on the screen. Drive to the location of Point B and press the Mark A-B button again to establish the A-B line. The CenterLine 250 will immediately begin providing navigation information with the lightbar and Navigation screen.

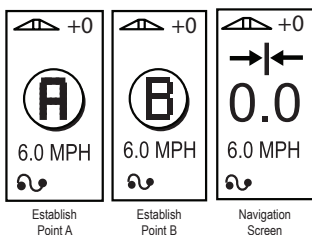

3. Press the Change Page button to view the Guidance and Application Control screens. During Guidance view, press the Enter button to enter into Guidance (Navigation View).

Press the Change Page key to change the screen views.

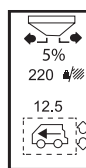

Application Control



Guidance Screen

Press the Enter key to view the Birds Eye View.



Birds Eye View

RETURN TO POINT

Press the Return to Point button to establish a point in memory. Normal guidance will continue uninterrupted during this process.

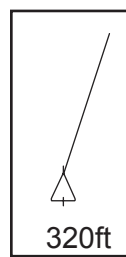
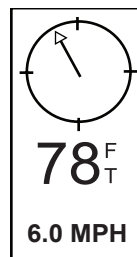

To navigate back to the established point, press the Return to Point button again. The Return to Point screen will be displayed and will provide navigation assistance to return to the established point.

Press the Enter button to view the Guidance (Navigation View) screen.



A+ NUDGE FEATURE

The A+ Nudge feature allows the existing A-B guideline to be shifted to the vehicle's current location. Press the Mark A-B  button immediately followed by pressing the Plus button.

Press the Escape  button from the Mark A Screen (after having pressed the Mark A-B  button) to leave the page without saving the changes and return to the Guidance Screen.



P.O. Box 630
470 South Wayside Street
Cornelia, Georgia 30531
Toll Free: (800) 282-3570
www.bbispreaders.com
